

J. F. FIFE.
MACHINE FOR CORRUGATING TUBING.

No. 426,439.

Patented Apr. 29, 1890.

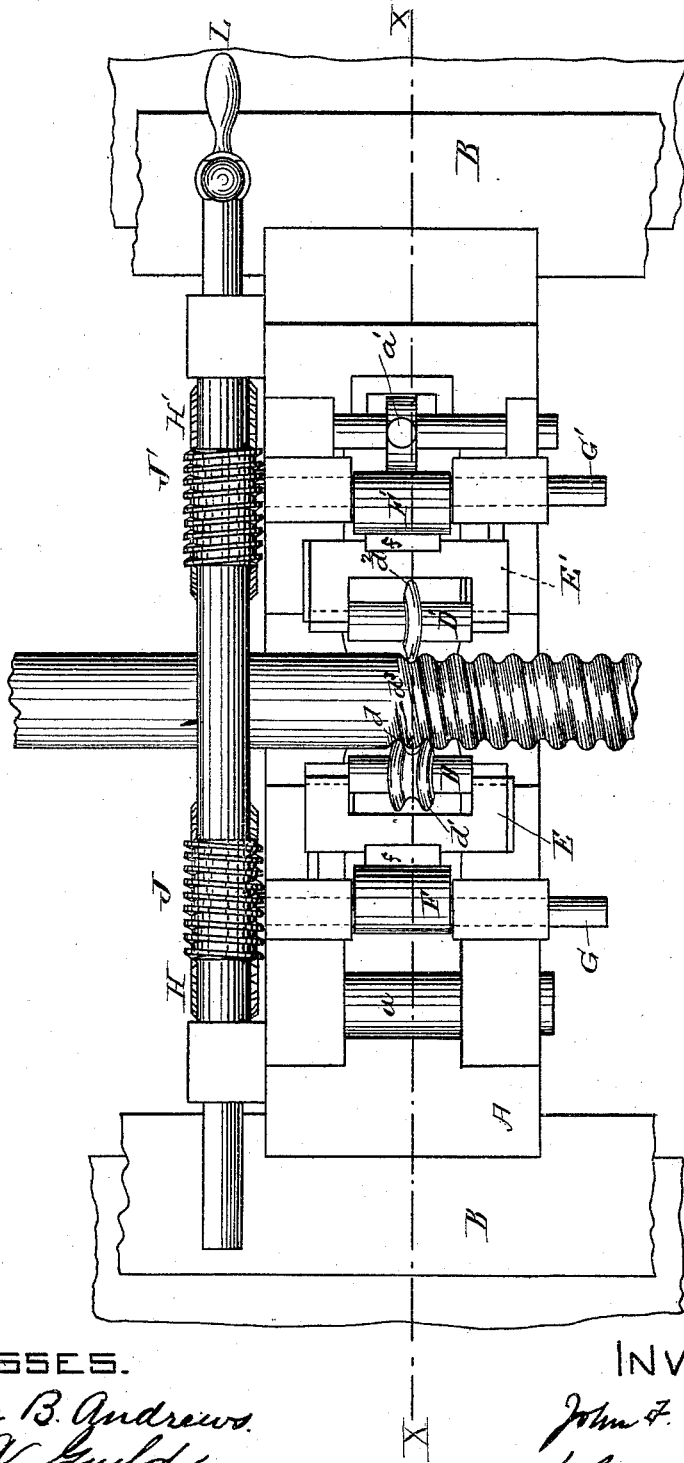

FIG. 1.

WITNESSES.

Hiram B. Andrews.
Eva A. Guild.

INVENTOR.

John F. Fife
J. George O. C. Coan
his Attorney

J. F. FIFE.
MACHINE FOR CORRUGATING TUBING.

No. 426,439.

Patented Apr. 29, 1890.

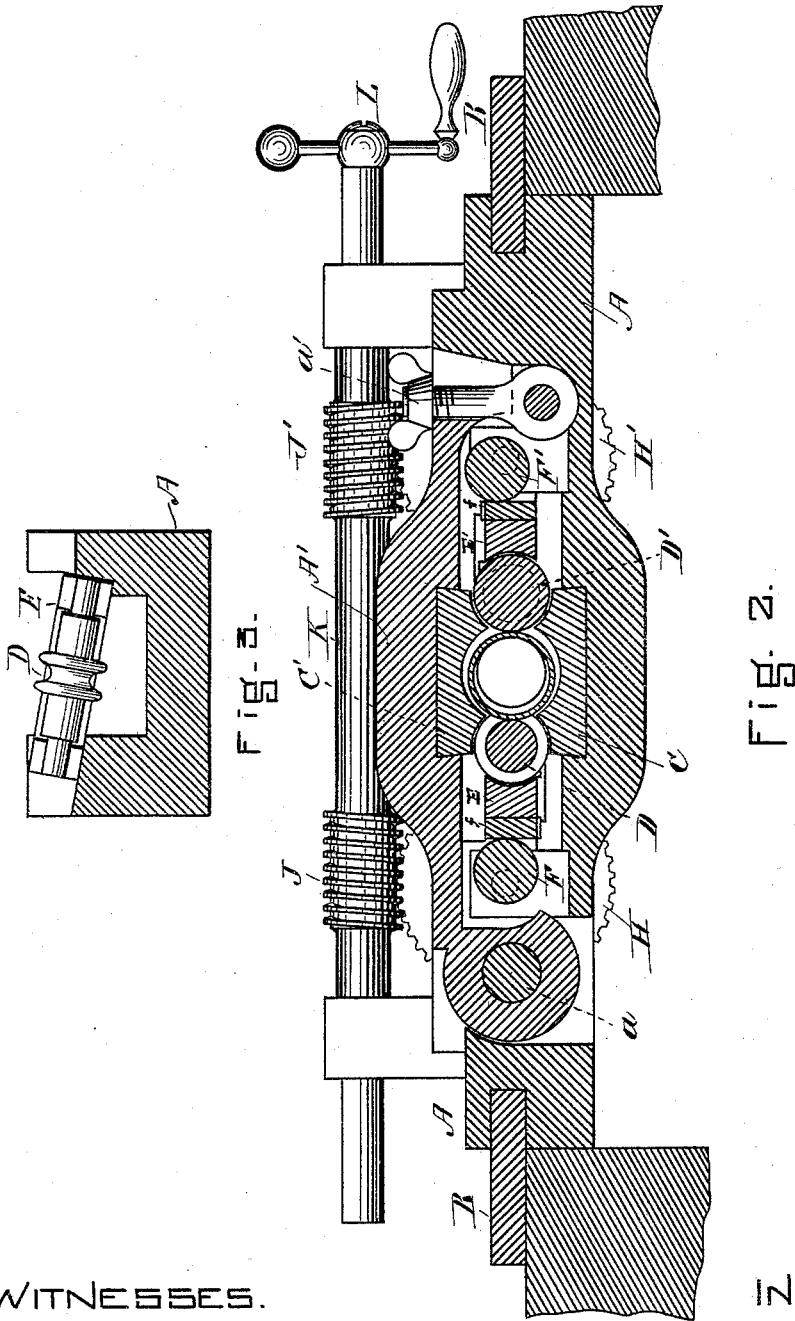

WITNESSES.

Hiram B. Andrews
Eva A. Guild

INVENTOR.

John F. Fife
J. G. O. G. Brule
his attorney -

(No Model.)

3 Sheets—Sheet 3.

J. F. FIFE.
MACHINE FOR CORRUGATING TUBING.

No. 426,439.

Patented Apr. 29, 1890.

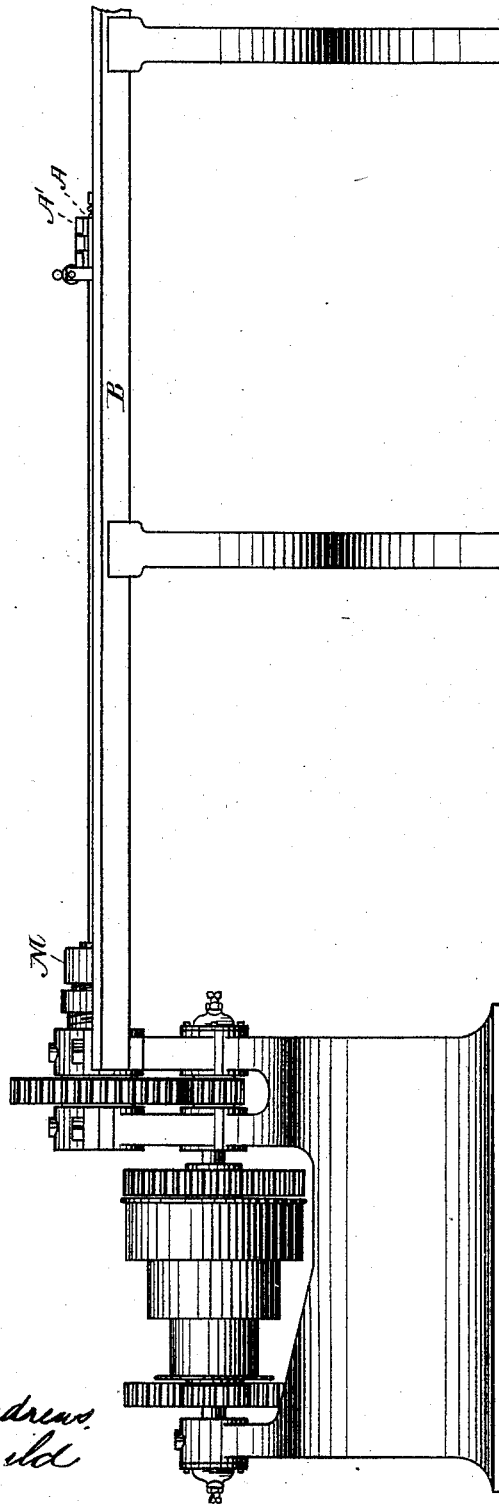

FIG. 4-

WITNESSES.

Hiram B. Andrews
Era A. Guild

INVENTOR.

John F. Fife
J. George D. G. Bonds
his attorney

UNITED STATES PATENT OFFICE.

JOHN F. FIFE, OF MEDFORD, MASSACHUSETTS, ASSIGNOR TO THE WAIN-
WRIGHT MANUFACTURING COMPANY, OF MASSACHUSETTS.

MACHINE FOR CORRUGATING TUBING.

SPECIFICATION forming part of Letters Patent No. 426,439, dated April 29, 1890.

Application filed July 22, 1889. Serial No. 318,206. (No model.)

To all whom it may concern:

Be it known that I, JOHN F. FIFE, a citizen of the United States, residing at Medford, county of Middlesex, and State of Massachusetts, have invented a new and useful Improvement in Machines for Corrugating Tubing, of which the following is a specification.

Machines have heretofore been made in which the tool-carriage and the tube have a rotating and longitudinal movement with relation to each other, and the tool or tools and the tube-support are of such character and so located with respect to each other that the tube while being corrugated by the tool or tools will be supported wherever necessary, so that it cannot bulge outwardly or be crushed out of the shape which it is desired that the tool shall give it. Such machines, however, have been crude in their method of holding and feeding the tools and have had no positive means of adjustment whereby the depth of the indentation could be governed with accuracy.

My improvement relates especially to the construction of the carriage and the arrangement and adjustment therein of the corrugating-tools, and will be understood by reference to the drawings, in which two views of the carriage are shown.

Before describing the drawings in detail it is necessary to bear in mind that the carriage herein referred to is adapted to slide on the ways of a lathe, and that the tube which is to be corrugated is to be gripped at one end by a chuck in the head-stock of such a lathe in a way well known to those skilled in the art. The tube is rotated, and the part upon which the corrugating is to be done lies in the sleeve formed in the carriage, the axis of the sleeve being coincident with the axis of the chuck, and the carriage being given its longitudinal motion along the ways by means of the rotations of the tube acting in connection with the corrugating-tools, the axes of which are set at an angle to the axis of the tube.

Figure 1 is a plan of the carriage, the upper half of the carriage being removed; and Fig. 2 is a cross-section on line *xx* of Fig. 1. Fig. 3 shows the position of the tool in its slide,

and Fig. 4 is an elevation showing the entire machinery in operation.

The carriage is made in two parts—a lower part A, which rests and slides upon the ways B on the lathe-bed. The upper part A' is 55 hinged thereto at *a*, and is held in place at its farther end by the screw *a'*. This carriage contains two blocks C C', each so shaped that together they form a hollow cylindrical passage through which the tube to be corrugated may pass, which passage is called the "sleeve." 60

D D' are tools so located that they may be projected into or withdrawn from the interior of this cylindrical passage. The tool D is 65 provided with two projecting corrugations *d* *d'*, and the tool D' with one projecting corrugation *d*², and these two tools are located opposite to each other and at an angle each to the other and to the axis of the cylindrical 70 passage referred to, as and for the purpose below described. The axle of each tool is mounted in a slide E E', so as to be free to rotate therein. The carriage A A' is recessed, as shown, on each side of the blocks, so as to 75 hold in each recess one of the slides E E', each recess being so formed that its slide may be moved toward and from the axis of the sleeve, but will be held from motion in any other 80 direction. The recesses are also so formed that the slides will be held at an angle to the axis of the sleeve, as above referred to. Behind each slide E E' is located a cam F F'. These cams are mounted upon shafts G G', 85 journaled in suitable bearings in the bed of the carriage A. Each shaft G G' is operated by a worm-gear H H', meshing into its worm J J', mounted upon the shaft K and operated by a crank-handle L. The worms J J' and their gears H H' are so arranged as to rotate 90 the shafts G G' in opposite directions. A block *f* of hard steel is placed between the cam F F' and its slide E E' to prevent the slide from being worn by the cam.

In order to operate my carriage, it having 95 been placed upon a lathe-bed, as shown, the carriage is first opened by loosening the thumb-screw *a'* and lifting the hinged part A'. The tube is laid into the sleeve, and, one end of it having first been plugged to prevent 100

it from being collapsed by the chuck M, is then placed in the chuck M, which is tightened in order to hold it fast. The carriage is then slid along until it reaches one extremity of the proposed corrugation. The part A' is then dropped into place and tightened by means of the thumb-screw a' . The handle L is then turned in such a way as to move the slides E E', and consequently their tools, so that the tools will bear upon the tube.

It has been said above that the axes of the tools should be at an angle to each other and to the axis of the sleeve. The purpose of this is to govern the pitch of the thread of the corrugation in the spirally-corrugated tube, and also to enable the tools to feed the carriage along the tube and so corrugate the entire length in a way well understood.

The cams are arranged with respect to each other as shown in Fig. 2, so that the cam F, controlling the tool D, is slightly advanced in position over the cam F', which controls the tool D', so that the tool D finishes its advance before the tool D'. One projection—say d of the tool D—strikes the plain tube first and tracks or slightly indents a spiral corrugation therein. Into this track follows the projection d^2 of the tool D, and immediately thereafter the other projection d' of the tool D. These three projections, acting together and one after the other on all sides of the rotating tube, perfect the corrugation of the tube. When these tools have passed over the length of the tube to be corrugated, the direction of rotation of the tube may be reversed by reversing the lathe, and the carriage will travel back over the same ground again, the handle L being given a sufficient turn to cause the tools to grip the tube a second time and corrugate it deeper. This process may be continued profitably until the tools have passed over the tube about six times. The tool D being advanced farther into the sleeve by its cam than the tool D', its receding portion d^3 acts as a female die upon the projecting corrugation of the tube, the tube being forced into this die by the tool D', and it serves to feed down the metal from the projecting corrugation of the tube to be worked by the projecting parts of the tools.

I have described above a machine which embodies, so far as I know, the best form of my invention. Other arrangements of tools, however, in relation to each other are possible, the requirement only being that there should be at least two tools located at substantially equal distances about the sleeve. It is best where only two tools are used that one of them should have two projecting working-surfaces, like $d d'$ on the tool D; but fairly good corrugations may be made in a carriage like that described, but in which the tool D is omitted and there is substituted for it a tool having one projecting corrugation d^2 and a part corresponding to the part d^3 , which shall ride upon the projecting corrugation of the tube. Moreover, a set of friction-rolls or

bearing-surfaces may be substituted for the sleeve, which is intended only to keep the tube in symmetrical condition while it is being corrugated; and in this case with a tube of given diameter the friction-rolls or bearing-surfaces must be so located as to bear upon the outer surface of the tube to be corrugated, and must be sufficient in number or in effective area to keep the tube symmetrical during the process of corrugation without the use of a mandrel. Under these circumstances only will they perform the function of such a tube-support as my invention calls for.

What I claim as my invention is—

1. In a tube-corrugating machine, in combination with the head-stock, a carriage free to slide upon a lathe-bed in either direction and provided with a tube-support located to surround the tube to be corrugated and keep it symmetrical during the process of corrugation, and two or more corrugating-tools located on opposite sides of said tube-support, all arranged together substantially as and for the purposes set forth.

2. In the carriage of a corrugating-machine provided with a tube-support, two adjustable rotary tools located opposite each other, in combination with means whereby one tool is projected into said tube-support slightly in advance of the other, all as and for the purposes set forth.

3. In a carriage of a corrugating-machine provided with a tube-support, two adjustable rotary tools located opposite each other, in combination with means whereby one tool is projected into the tube-support slightly in advance of the other and reaches the innermost limit of its motion and is delayed there, while the other tool is still caused to advance, all substantially as and for the purposes set forth.

4. In a tube-corrugating carriage provided with a tube-support, two or more tools D, each mounted in a slide E, in combination with a cam F, mounted upon a shaft G, said shafts being operated from the same source of power, all as set forth.

5. In a tube-corrugating machine, in combination with a tube-support located to surround the tube to be corrugated, two rotary tools located to bear upon opposite portions of the exterior of the tube to be corrugated, one of said tools being provided with a single projecting corrugation, the other tool being provided with two corrugations and an intervening receding corrugation, said tools being so located with respect to each other that the single projection of one tool will be opposite to the receding corrugation of the other tool, all substantially as described.

In testimony whereof I have hereunto subscribed my name this 10th day of July, A. D. 1889.

JOHN F. FIFE.

Witnesses:

PERCY N. KENWAY,
GEORGE O. G. COALE.

Correction in Letters Patent No. 426,439.

It is hereby certified that the assignee, the "Wainwright Manufacturing Company," in Letters Patent No. 426,439, granted April 29, 1890, upon the application of John F. Fife, of Medford, Massachusetts, for an improvement in "Machines for Corrugating Tubing," should have been described and specified as the *Wainwright Manufacturing Company of Massachusetts*; and that the said Letters Patent should be read with this correction therein that the same may conform to the record of the case in the Patent Office.

Signed, countersigned, and sealed this 6th day of May, A. D. 1890.

[SEAL.]

CYRUS BUSSEY,
Assistant Secretary of the Interior.

Countersigned:

C. E. MITCHELL,
Commissioner of Patents.